

| Technical Parameters |         |                   |                |     |      |      |      |       |     |     |     |    |     |               |                |
|----------------------|---------|-------------------|----------------|-----|------|------|------|-------|-----|-----|-----|----|-----|---------------|----------------|
| Model                | Opening | Volume<br>(Ltrs.) | Dimension (mm) |     |      |      |      |       |     |     |     |    |     | Base          | Weight<br>(kg) |
|                      |         |                   | D1             | D   | H±6  | H1   | H2   | L     | F   | WA  | WLA | WB | WLB |               |                |
| 10×13                | -2.5"   | 13.0              | 258            | 266 | 338  | 333  | 178  | 146.5 | 10  | 4.8 | 1.8 | 5  | 1   | Standard Base | 1.7            |
| 10×17                | -2.5"   | 16.4              | 258            | 266 | 429  | 425  | 245  | 146.5 | 50  | 4.8 | 1.8 | 5  | 1   | Standard Base | 2.8            |
| 10×19                | -2.5"   | 18.8              | 258            | 266 | 494  | 489  | 297  | 146.5 | 100 | 4.8 | 1.8 | 5  | 1   | Standard Base | 2.9            |
| 10×24                | -2.5"   | 25.0              | 258            | 266 | 622  | 617  | 425  | 146.5 | 100 | 4.8 | 1.8 | 5  | 1   | Standard Base | 3.4            |
| 10×35                | -2.5"   | 38.8              | 258            | 266 | 886  | 882  | 705  | 146.5 | 100 | 4.8 | 1.8 | 5  | 1   | Standard Base | 4.4            |
| 10×44                | -2.5"   | 50.0              | 258            | 266 | 1135 | 1130 | 935  | 146.5 | 100 | 4.8 | 1.8 | 5  | 1   | Standard Base | 4.8            |
| 10×54                | -2.5"   | 62.5              | 258            | 266 | 1380 | 1375 | 1195 | 146.5 | 100 | 4.8 | 1.8 | 5  | 1   | Standard Base | 6.0            |

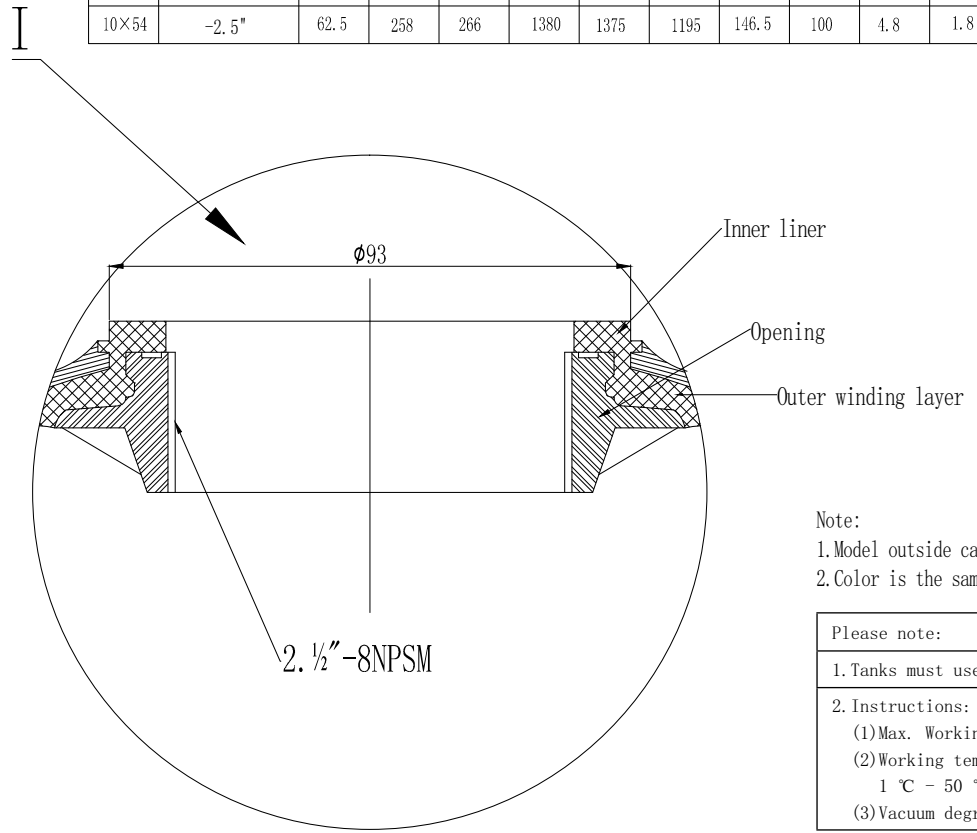
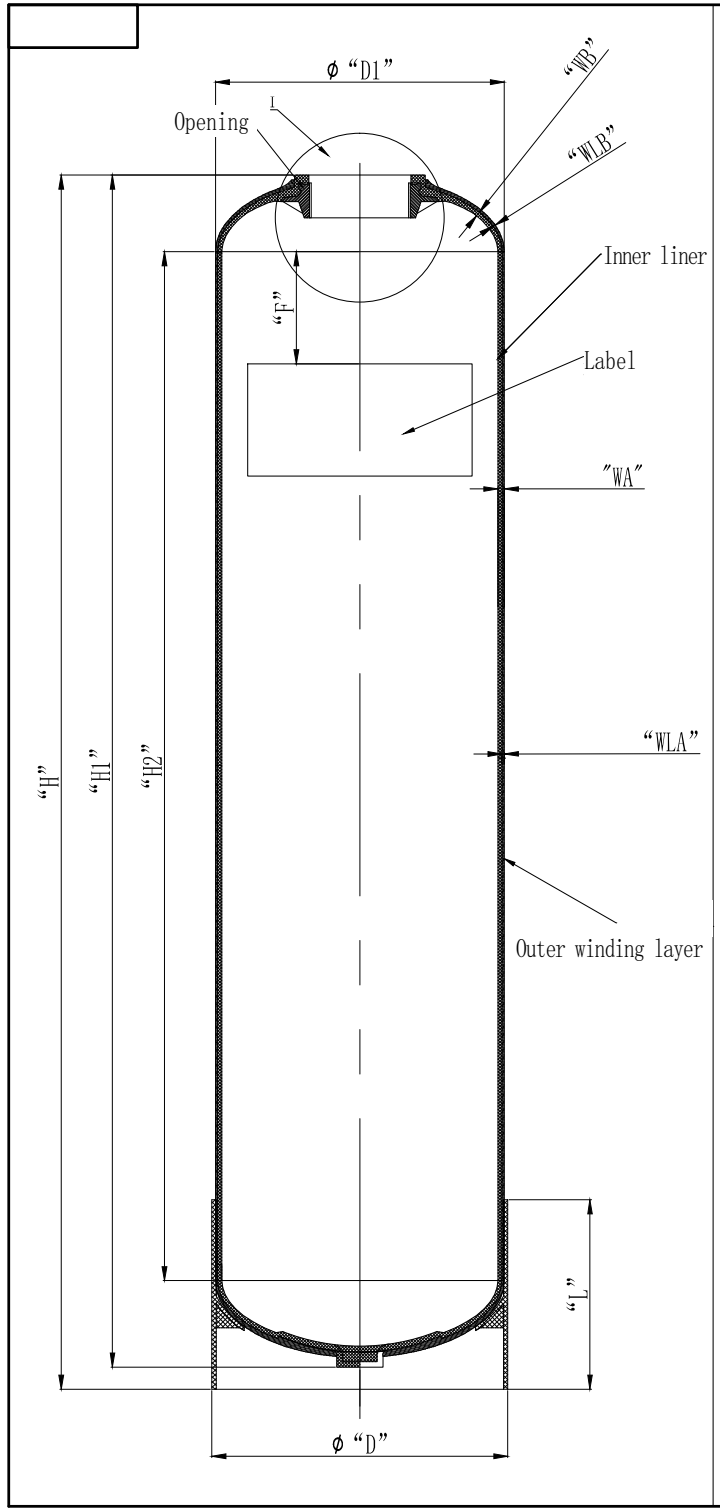

| 2 1/2" - 8NPSM Internal thread |              |
|--------------------------------|--------------|
| Medium Dia.                    | 2.762-2.768" |
| Small Dia.                     | 2.705-2.715" |
| Large Dia.                     | 2.843-2.849" |

- Note:
1. Model outside carton
  2. Color is the same as package tape color

|  |
|--|
| Please note:   |
| 1. Tanks must use with anti-vacuum valve.                  |
| 2. Instructions:   |
| (1) Max. Working pressure: 6 Bar (86 Psi)                  |
| (2) Working temperature:<br>1 °C - 50 °C (34 °F - 127 °F). |
| (3) Vacuum degree: 17 KPa (5"Hg)                           |

| Designer |               |            |
|----------|---------------|------------|
|          | Signature     | Date       |
| Designer | Song Ke Qiang | 2019.12.25 |
| Verify   |               |            |
| Approval |               |            |

| Hebei ChengDa HuaMo Technology Co., Ltd. |   |
|--|---|
| Material: FRP                            | Projection:                             |
| Model: 10-2.5"                           | Name: FRP softener tanks                |
| Version NO.: 00                          | Drawing NO.: CD-19-10-02/03             |
| 1/1 page                                 | Unit: mm<br>Do not measure drawing size |