

Technical Parameters															
Model	Opening	Volume (Ltrs.)	Dimension (mm)											Base	Weight (kg)
			D1	D	H±6	H1	H2	L	F	WA	WLA	WB	WLB		
16×52	-2.5"	150.1	418	428	1325	1317	1033	210	100	8	4	6	2	Standard Base	13.7
16×65	-2.5"	191.7	418	428	1668	1660	1365	210	100	8	4	6	2	Standard Base	15.8

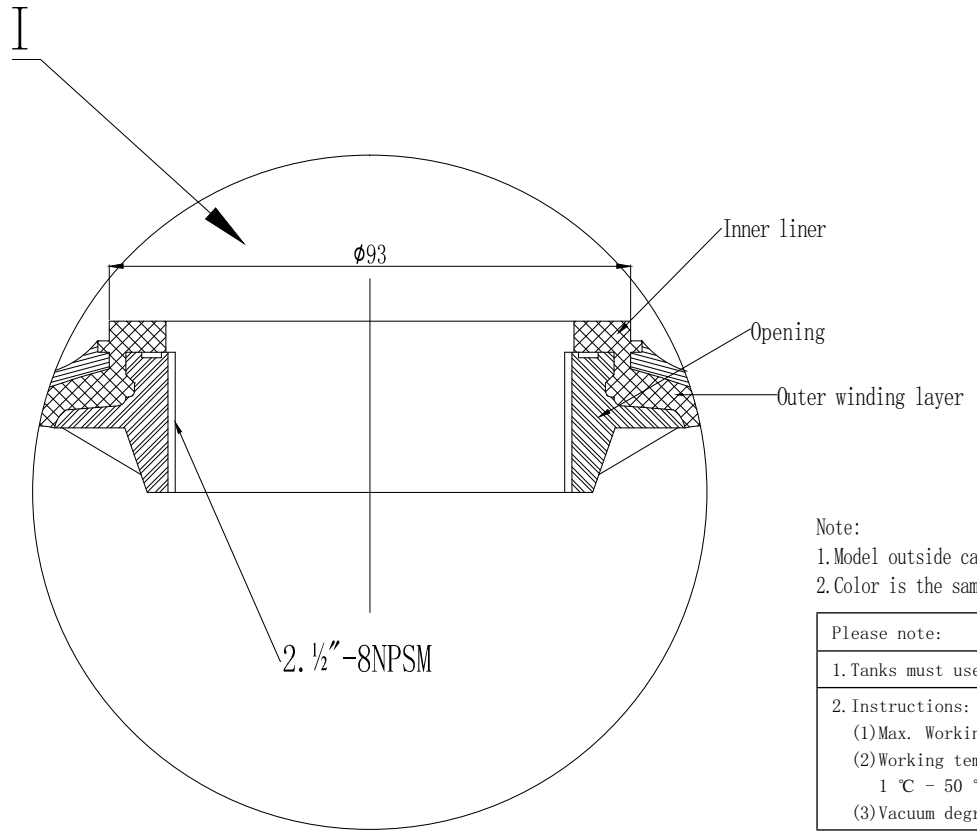
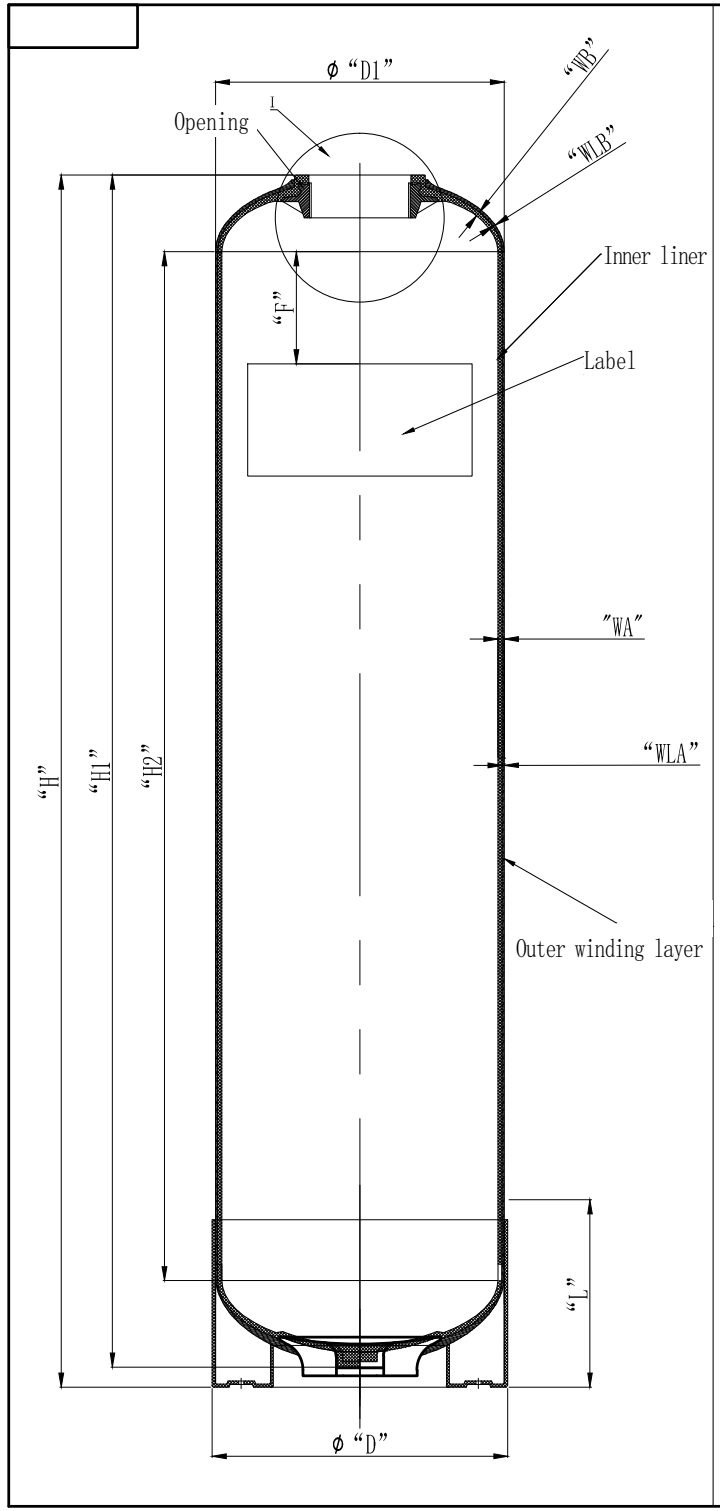

2 1/2"-8NPSM Internal thread	
Medium Dia.	2.762-2.768"
Small Dia.	2.705-2.715"
Large Dia.	2.843-2.849"

- Note:
1. Model outside carton
 2. Color is the same as package tape color

Please note:
1. Tanks must use with anti-vacuum valve.
2. Instructions:
(1) Max. Working pressure: 10.5 Bar (150 Psi)
(2) Working temperature: 1 °C - 50 °C (34 °F - 127 °F).
(3) Vacuum degree: 17 KPa (5"Hg)

Designer		
	Signature	Date
Designer	Song Ke Qiang	2019.12.25
Verify		
Approval		

Hebei ChengDa HuaMo Technology Co., Ltd.	
Material: FRP	Projection:
Model: 16"-2.5"	Name: FRP softener tanks
Version NO.: 00	Drawing NO.: CD-19-10-02/09
1/1 page	Unit: mm Do not measure drawing size