

### Technical Parameters

Model	Opening	Volume (Ltrs.)	Dimension (mm)											Base	Weight (kg)
			D1	D	H±10	H1	H2	L	F	WA	WLA	WB	WLB		
16×52	-4"-4"	150.1	418	415	1534	1317	1060	282	100	8	4	6	2	Tripod	14.8
16×65	-4"-4"	191.7	418	415	1877	1660	1390	282	100	8	4	6	2	Tripod	16.9

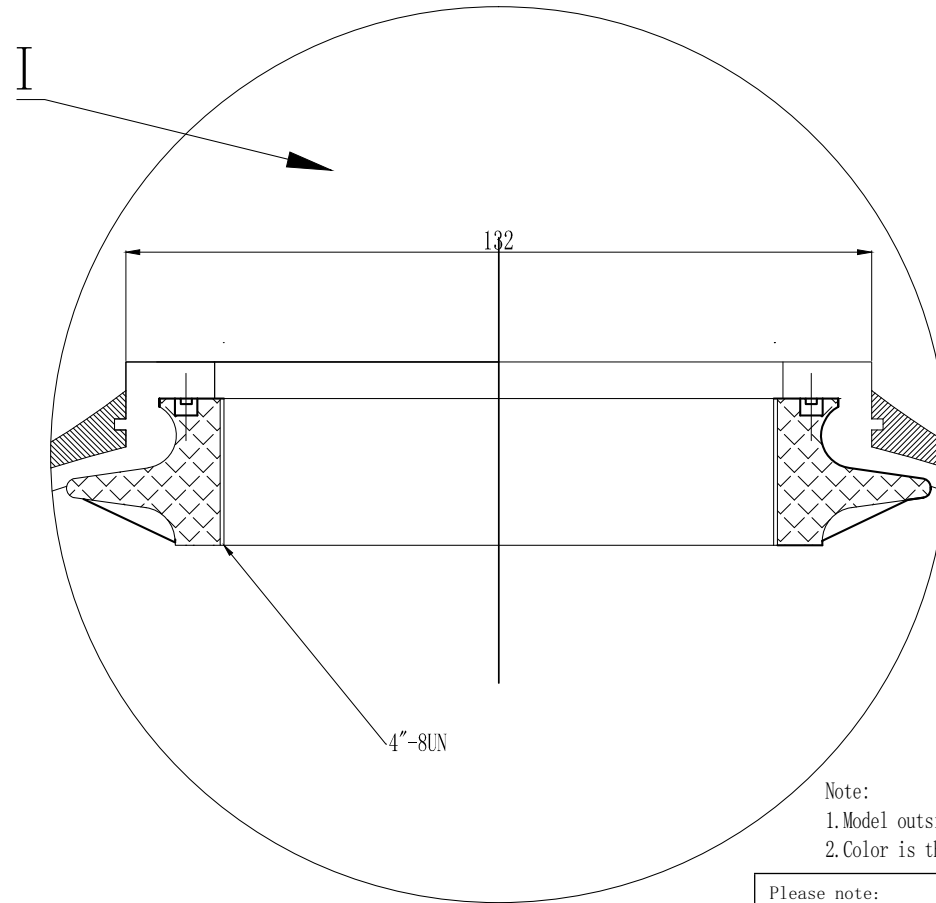

- Note:
- Model outside carton
  - Color is the same as package tape color

4"-8UN Internal thread	
Medium Dia	3.918-3.930"
Small Dia	3.865-3.875"
Large Dia	4.000-4.010"

- Please note:
- Tanks must use with anti-vacuum valve.
  - Instructions:
    - Max. Working pressure: 10.5 Bar (150 Psi)
    - Working temperature: 1 °C - 50 °C (34 °F - 127 °F).
    - Vacuum degree: 17 KPa (5"Hg)

Hebei ChengDa HuaMo Technology Co., Ltd.

Designer		
	Signature	Date
Designer	Song Ke Qiang	2019.12.25
Verify		
Approval		

Material: FRP	Projection:
Model: 16-4"-4"	Name: FRP softener tanks
Version NO.: 00	Drawing NO.: CD-19-10-02/11
1/1 page	Unit: mm Do not measure drawing size