

Technical Parameters

Model	Opening	Volume (Ltrs.)	Dimension (mm)											Base	Weight (kg)
			D1	D	H±10	H1	H2	L	F	WA	WLA	WB	WLB		
18×36	-4"	118.1	465	451	920	900	595	94	100	9	5	7	3	Round	13.6
18×53	-4"	186.5	465	451	1350	1330	1025	94	100	9	5	7	3	Round	20.1
18×65	-4"	235.0	465	451	1655	1635	1330	94	100	9	5	7	3	Round	23.5

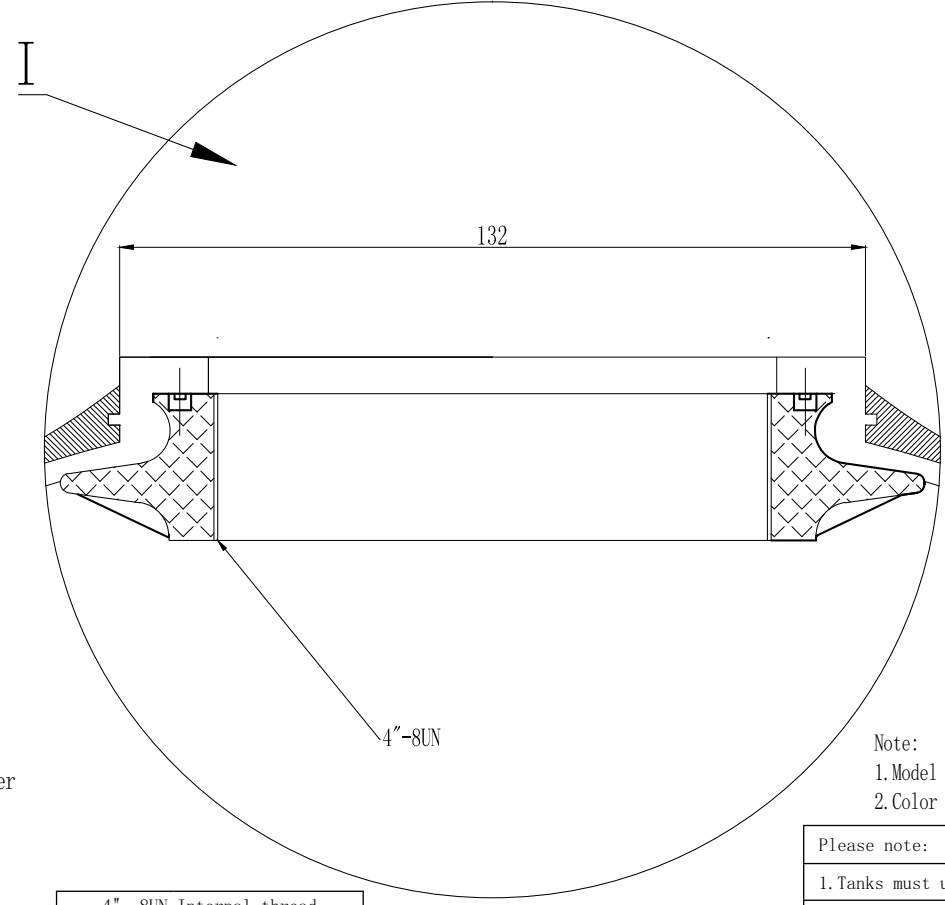

4"-8UN Internal thread	
Medium Dia	3.918-3.930"
Small Dia.	3.865-3.875"
Large Dia	4.000-4.010"

- Note:
1. Model outside carton
 2. Color is the same as package tape color

Please note:

1. Tanks must use with anti-vacuum valve.
2. Instructions:
 - (1) Max. Working pressure: 10.5 Bar (150 Psi)
 - (2) Working temperature: 1 °C - 50 °C (34 °F - 127 °F).
 - (3) Vacuum degree: 17 KPa (5"Hg)

Hebei ChengDa HuaMo Technology Co., Ltd.	
Material: FRP	Projection:
Model: 18-4"	Name: FRP softener tanks
Version NO.: 00	Drawing NO.: CD-19-10-02/12
1/1 page	Unit: mm Do not measure drawing size

Designer		
	Signature	Date
Designer	Song Ke Qiang	2019.12.25
Verify		
Approval		