

### Technical Parameters

Model	Opening	Volume (Ltrs.)	Dimension (mm)											Base	Weight (kg)
			D1	D	H±10	H1	H2	L	F	WA	WLA	WB	WLB		
21×62	-4"-4"	307.8	543	530	1804	1570	1229	304	100	9	5	7	3	Tripod	32

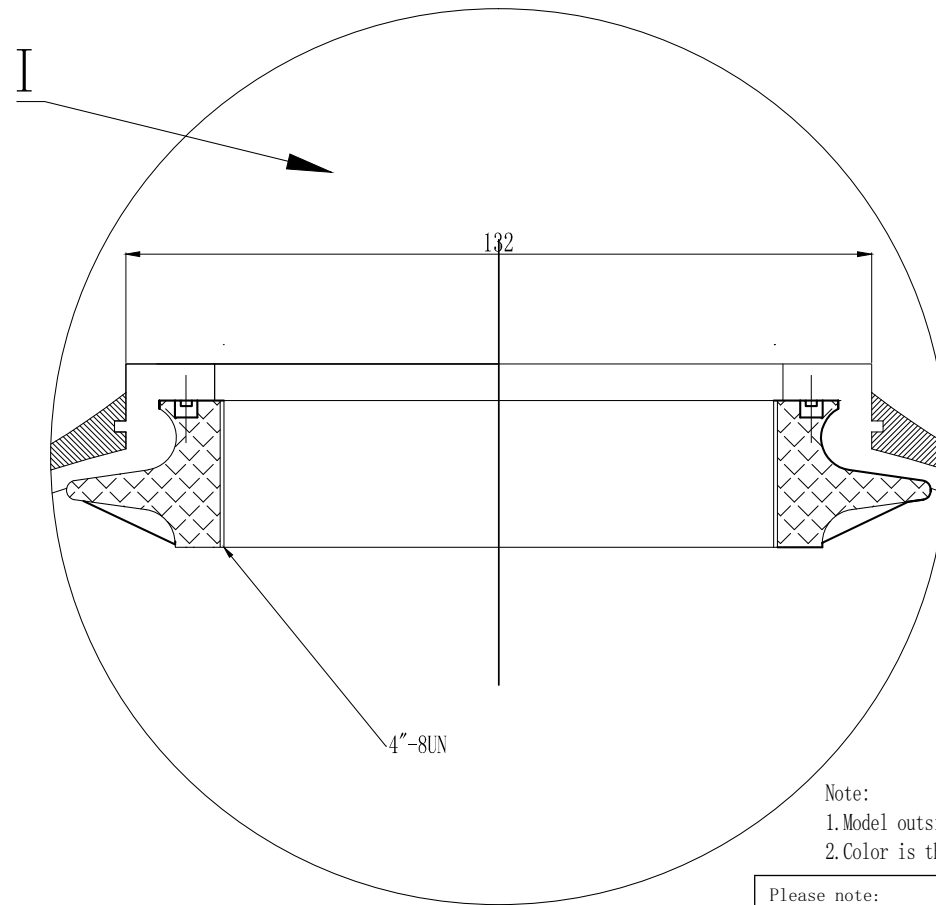

4"-8UN Internal thread	
Medium Dia	3.918-3.930"
Small Dia.	3.865-3.875"
Large Dia	4.000-4.010"

- Note:
1. Model outside carton
  2. Color is the same as package tape color

- Please note:
1. Tanks must use with anti-vacuum valve.
  2. Instructions:
    - (1) Max. Working pressure: 10.5 Bar (150 Psi)
    - (2) Working temperature: 1 °C - 50 °C (34 °F - 127 °F).
    - (3) Vacuum degree: 17 KPa (5"Hg)

Hebei ChengDa HuaMo Technology Co., Ltd.

Designer		
	Signature	Date
Designer	Song Ke Qiang	2019. 12. 25
Verify		
Approval		

Material: FRP	Projection:
Model: 21-4"-4"	Name: FRP softener
Version NO.: 00	Drawing NO.: CD-19-10-02/17
1/1 page	Unit: mm D  not measure drawing size