

Technical Parameters

Model	Opening Size	VOL (Ltrs.)	Size Parameters (mm)											Base	Weight (kg)
			D1	D	H±6	H1	H2	L	F	WA	WLA	WB	WLB		
09X17	2.5"T/B	13.8	231	239	581	425	275	285	50	5	2	5	1	Cylindrical high	3.1±0.2

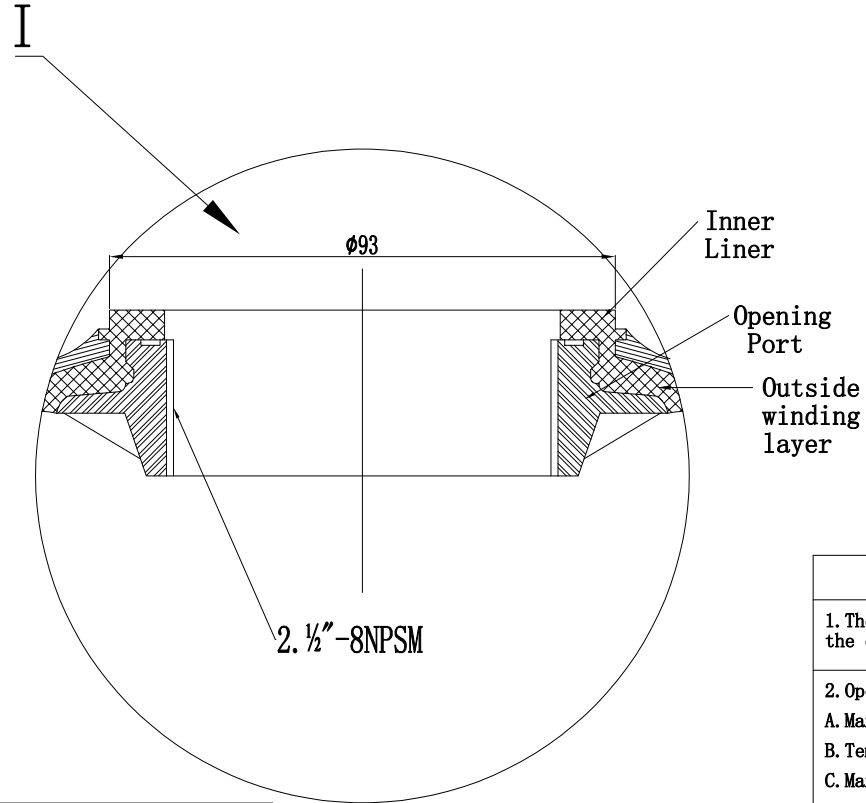
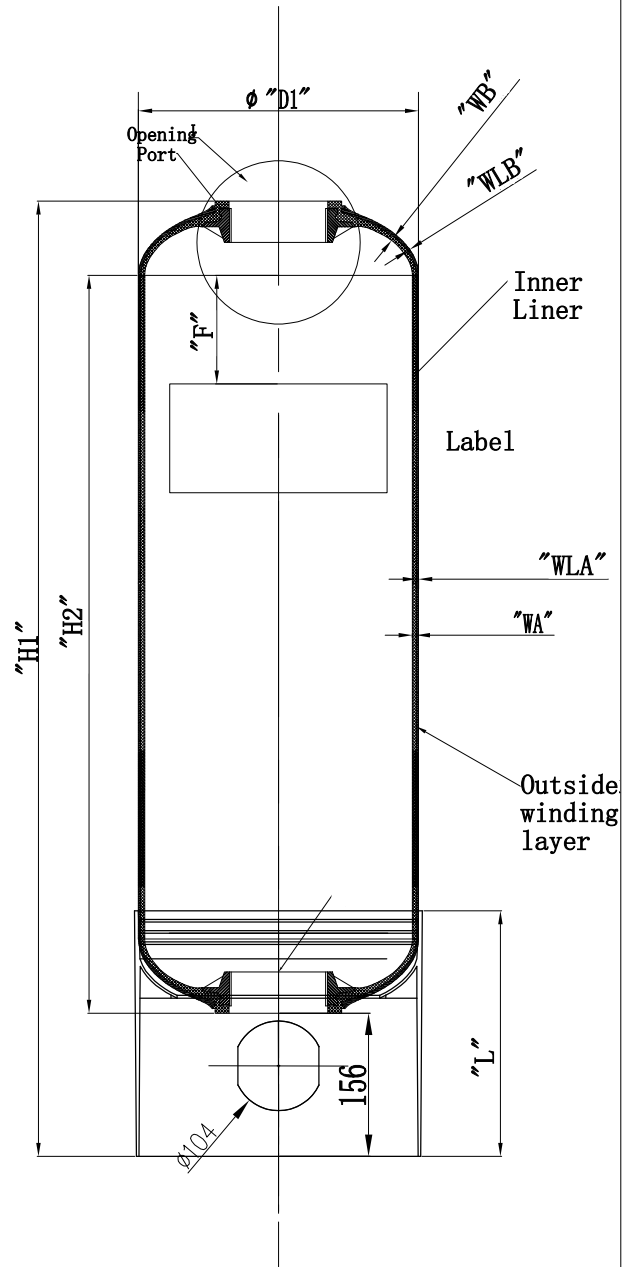

2. 1/2"-8NPSM Internal thread	
Medium Dia	2.762-2.768"
Small Dia	2.705-2.715"
Large Dia	2.843-2.849"

Note:

- The vacuum valve must be installed on the device.
- Operation Instructions:
 - Max working pressure: 10.5Bar (150Psi)
 - Temperature Range: 1-50°C (34-127°F)
 - Maximum vacuum: 17Kpa (5"Hg)

Remark

- Product type identification see outer packaging logo.
- The product color is consistent with the color of the tape packaging box.

Sign			Hebei Chengda WaterTechnology Co.,Ltd.		
	Signature	Date	Material:	FRP	Projection:
Designer	Chengyang Sun	2024.7.16	Model:	9" 2.5"T/B	Name: FRP tank
Review	Jingwei Hu	2024.7.18	Version number: 00	Description of Change Version	Drawing No. CD-23-04-05/001
Approve			Please don't measure the size of the drawing		Unit: mm 1 Page Page 1