

Technical Parameters															
Model	Opening Size	VOL (Ltrs.)	Size Parameters (mm)											Base	Weight (kg)
			D1	D	H±6	H1	H2	L	F	WA	WLA	WB	WLB		
10X54	T/B 2.5"	62.5	258	266	1522	1363	1195	285	100	4.8	1.8	5	1	Round	6.6±0.4

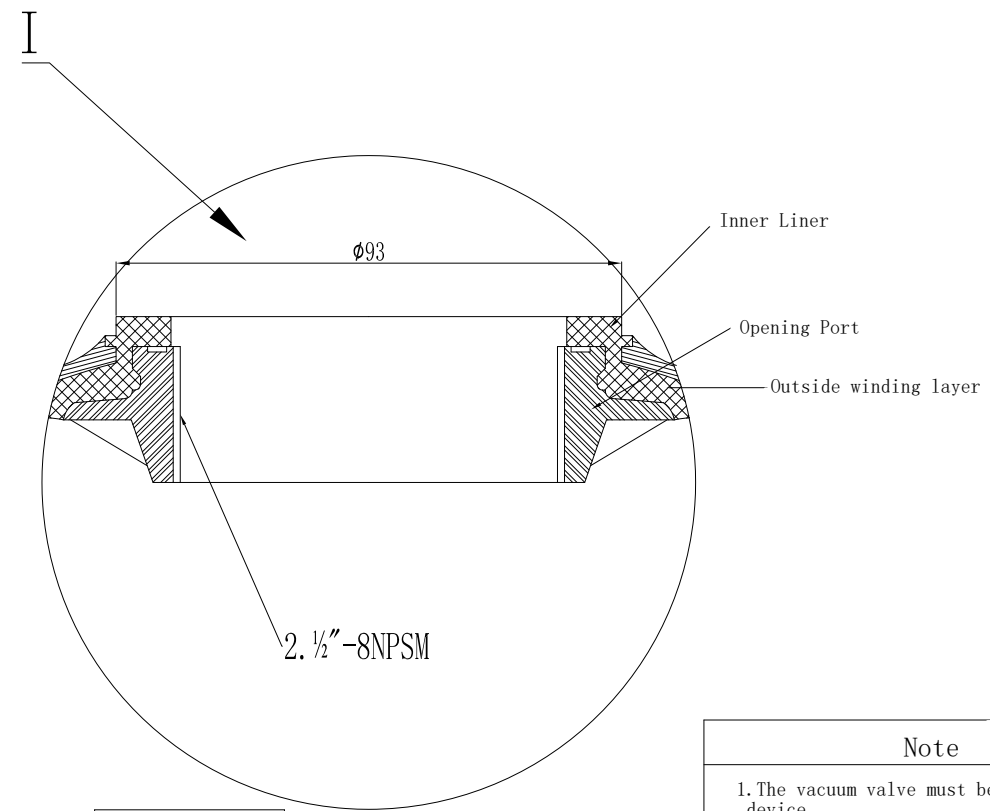

2. 1/2 inch-8NPSM internal thread	
Middle Dia	2.762-2.768"
Min Dia	2.705-2.715"
Max Dia	2.843-2.849"

Note

1. The vacuum valve must be installed on the device.

Operation Instructions
 A. Max working pressure 8 bar (125Psi)
 B. Temperature Range: 1-50°C (34-127°F)
 C. Maximum vacuum: 17Kpa (5" Hg)

Remark
 1. Product type identification see outer packaging logo.
 2. The product color is consistent with the color of the tape packaging box.

Sign		Hebei Chengda WaterTechnology Co.' Ltd.			
	Signature	Date	Material	FRP	Projection
Designer	Chengyang Sun	2024.07.18	Model	10" in diameter, 2.5, top port	Name: FRP tank
Review	Jingwei Hu	2024.07.18	Version number: 00	Description of Change Version	Drawing No. CD-22-09-27/01
Approve			Please don't measure the size of the drawing		Unit: mm

1 Page Page 1