

Technical Parameters															
Model	Opening Size	VOL (Ltrs.)	Size Parameters (mm)											Base	Weight (kg)
			D1	D	H±10	H1	H2	L	F	WA	WLA	WB	WLB		
18X65	6"T/B	235.0	465	450	2010	1767	1330	283	100	9	5	7	3	Triangular	28±1.5

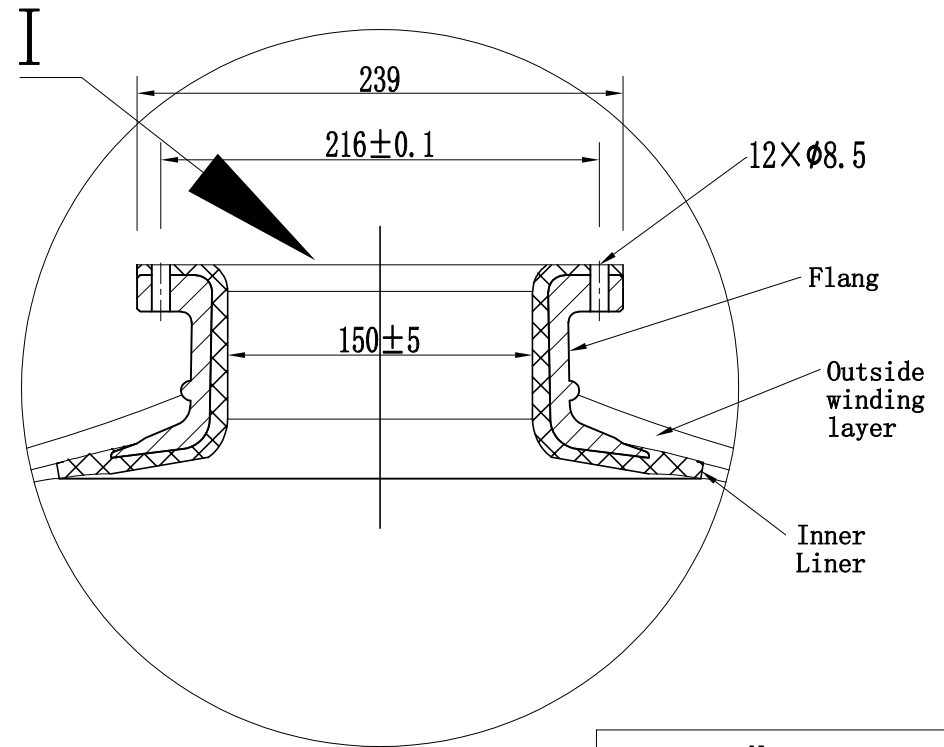

Note:

- The vacuum valve must be installed on the device.
- Operation Instructions:
 - Max working pressure: 10.5Bar (150Psi)
 - Temperature Range: 1-50°C (34-127°F)
 - Maximum vacuum: 17Kpa (5"Hg)

Remark
 1. Product type identification see outer packaging logo.
 2. The product color is consistent with the color of the tape packaging box.

Sign			Hebei Chengda WaterTechnology Co., Ltd.			
	Signature	Date	Material:	FRP	Projection:	$\triangleleft \oplus$
Designer	Chengyang Sun	2024. 7. 16	Model:	18", 6"T/B	Name:	FRP tank
Review	Jingwei Hu	2024. 7. 18	Version number:	00	Description of Change Version	Drawing No. CD-22-09-28/44
Approve			Please don't measure the size of the drawing		Unit: mm	1 Page Page 1