

Technical Parameters

Model	Opening Size	VOL (Ltrs.)	Size Parameters (mm)										Base	Weight (kg)	
			D1	D	H±10	H1	H2	L	F	WA	WLA	WB			WLB
20×69	上4"	307	512	500	1770	1740	1365	110	100	9	5	7	3	Round	27±2

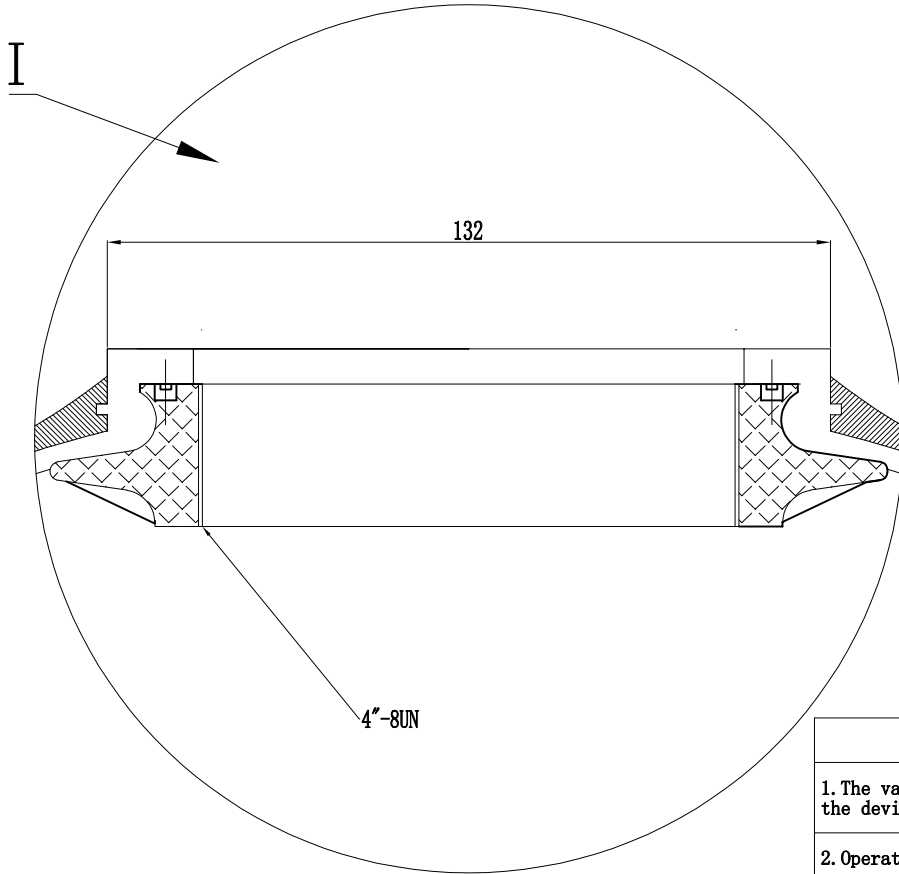
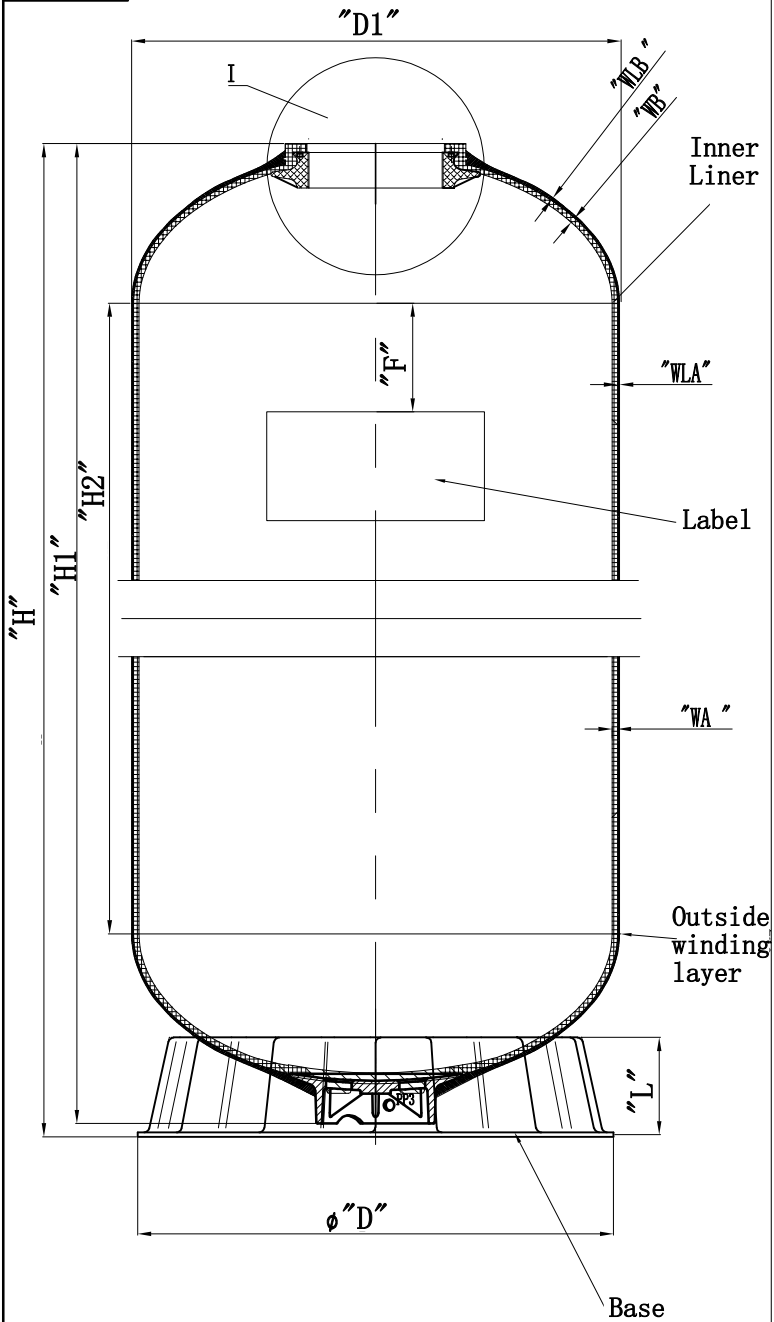

4"-8UN	Internal thread
Middle Dia	3.918-3.930"
Min Dia	3.865-3.875"
Max Dia	4.000-4.010"

Remark
 1. Product type identification see outer packaging logo.
 2. The product color is consistent with the color of the tape packaging box.

Note:
 1. The vacuum valve must be installed on the device.
 2. Operation Instructions:
 A. Max working pressure: 10.5Bar (150Psi)
 B. Temperature Range: 1-50°C (34-127°F)
 C. Maximum vacuum: 17Kpa (5"Hg)

Sign			Hebei Chengda WaterTechnology Co.,Ltd.			
	Signature	Date	Material:	FRP	Projection:	
Designer	Chengyang Sun	2024. 7. 16	Model:	20", 4"T	Name:	FRP tank
Review	Jingwei Hu	2024. 7. 18	Version number: 00	Description of Change Version	Drawing No.	CD-22-09-28/48
Approve			Please don't measure the size of the drawing		Unit: mm	1 Page Page 1