

Technical Parameters

Model	Opening Size	VOL (Ltrs.)	Size Parameters (mm)											Base	Weight (kg)
			D1	D	H±25	H1	H2	L	F	WA	WLA	WB	WLB		
36×65	T 4"	860.0	909	921	1700	1654	1120	207	100	9.5	4.5	9.5	3	Round	60±5
36×72	T 4"	969.2	909	921	1880	1834	1300	207	100	9.5	4.5	9.5	3	Round	66±5

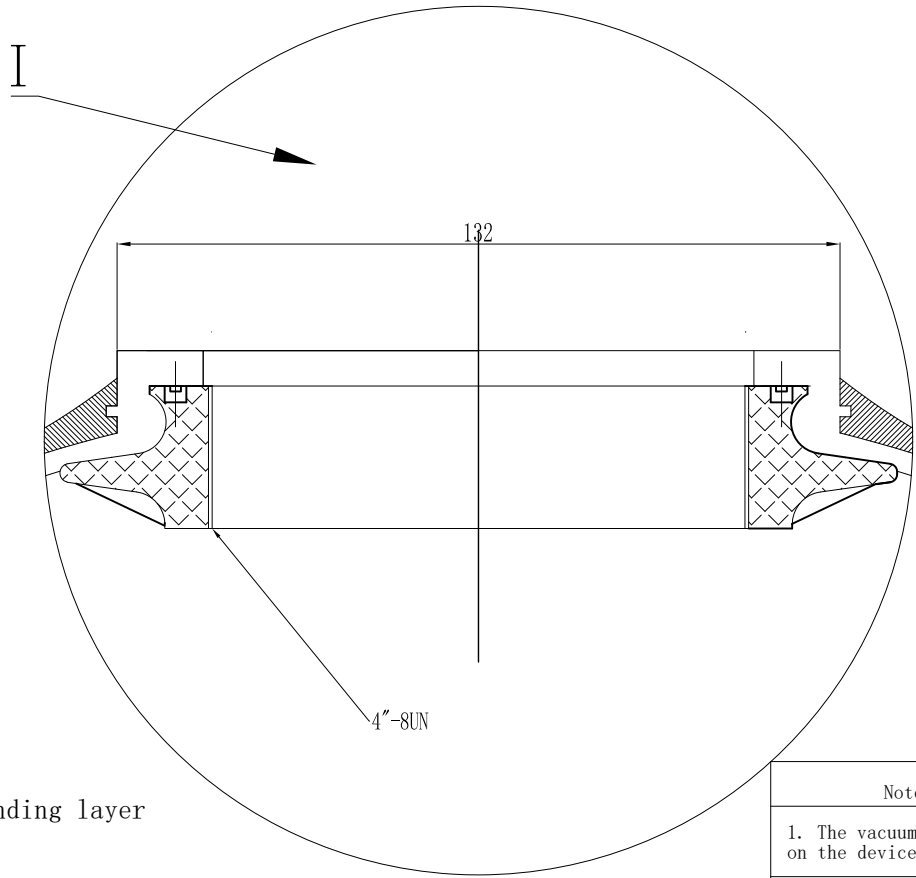
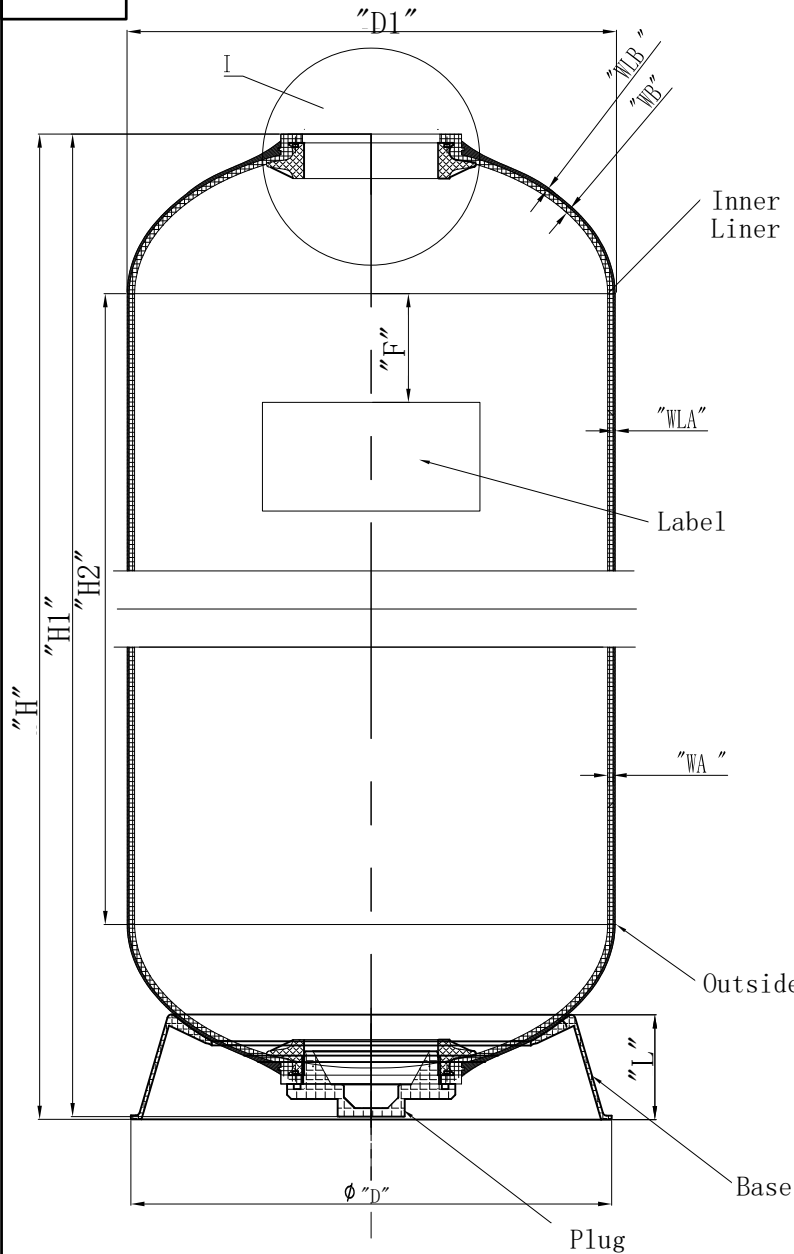

4"-8UN internal thread	
Middle Dia	3.918-3.930"
Min Dia	3.865-3.875"
Max Dia	4.000-4.010"

Note
1. The vacuum valve must be installed on the device.
2. Operation Instructions: A. Max working pressure: 8bar (125Psi) B . Temperature Range: 1-50°C (34-127°F) C. Maximum vacuum: 17Kpa (5"Hg)

Sign			Hebei Chengda WaterTechnology Co., Ltd.			
	Signature	Date	Material:	FRP	Projection:	
Designer	Chengyang Sun	2024.07.18	Model:	36" T 4"	Name: FRP tank	
Review	Jingwei Hu	2024.07.18	Version number: 00	Description of Change Version	Drawing No. CD-22-09-27/37	
Approve			Please don't measure the size of the drawing		Unit: mm	1 Page Page 1