

Technical Parameters

| Model | Opening Size | VOL (Ltrs.) | Size Parameters (mm) | | | | | | | | | | | Base | Weight (kg) |
|-------|--------------|----------------|----------------------|------|------|------|-----|-----|-----|------|-----|-------|-----|------------|----------------|
| | | | D1 | D | H±30 | H1 | H2 | L | F | WA | WLA | WB | WLB | | |
| 63×67 | T/B 6"-U-D | 2629.8 | 1609 | 1600 | 2110 | 1865 | 565 | 535 | 100 | 14.5 | 8.3 | 112.5 | 5.3 | Triangular | 202±15 |
| 63×86 | 6386-6-6-U-D | 3424.5 | 1601 | 1600 | 2460 | 2215 | 905 | 535 | 100 | 14.5 | 8.3 | 12.5 | 5.3 | Triangular | 228±15 |

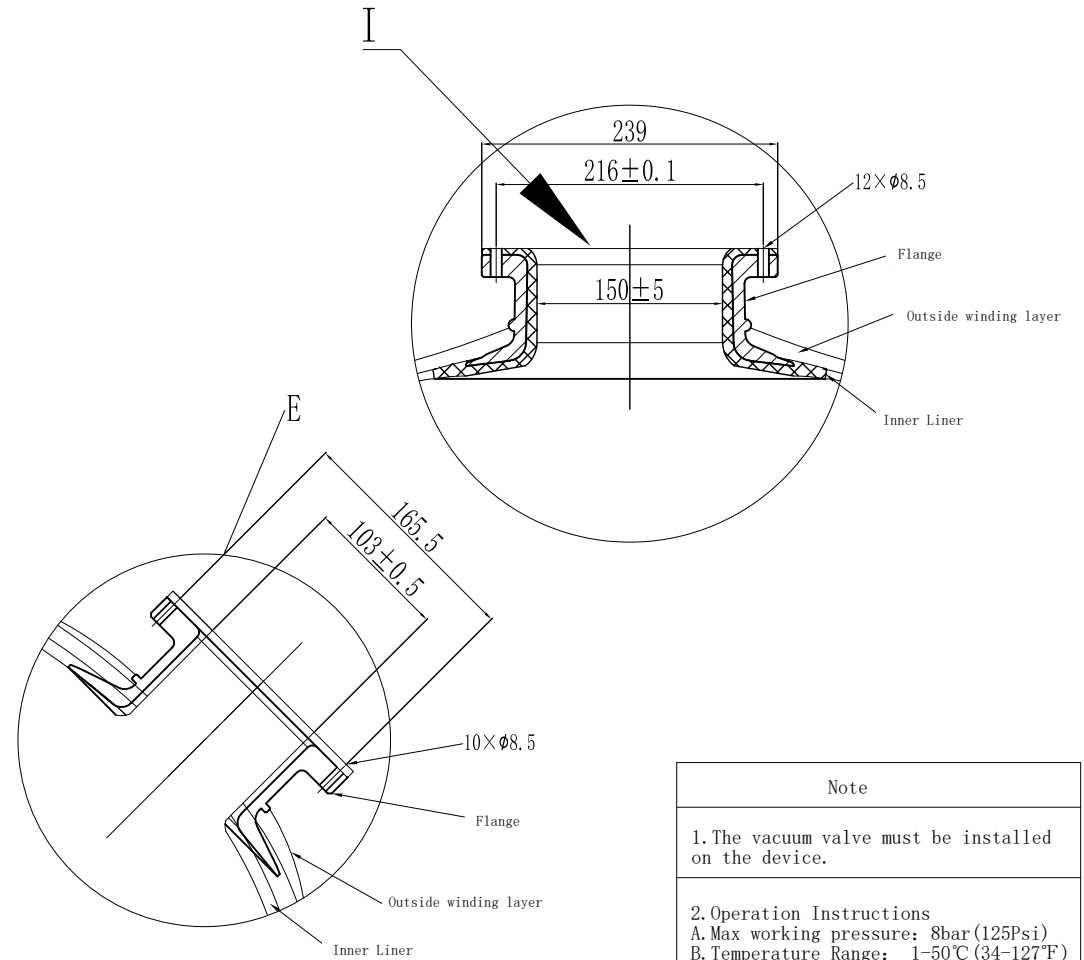
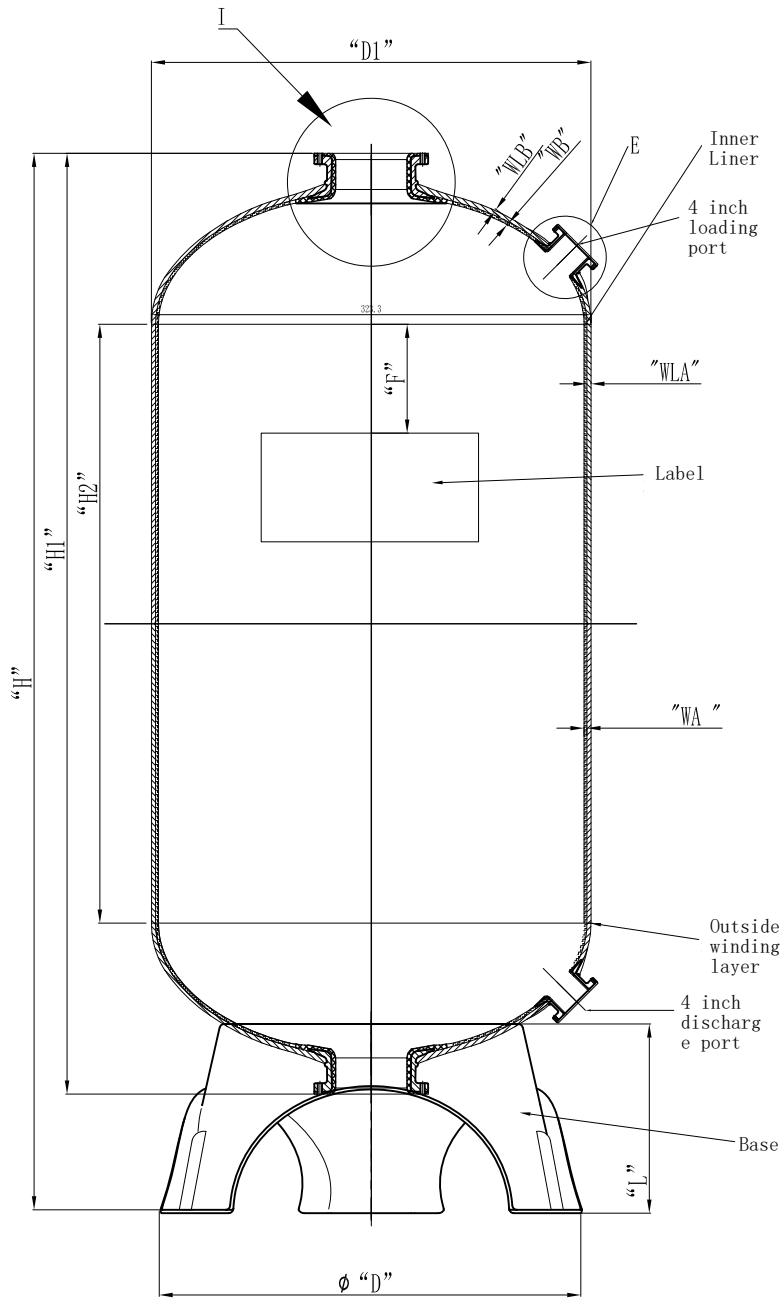

Note

1. The vacuum valve must be installed on the device.

2. Operation Instructions
 A. Max working pressure: 8bar (125Psi)
 B. Temperature Range: 1-50°C (34-127°F)
 C. Maximum vacuum: 17Kpa (5" Hg)

Remark
 1. Product type identification see outer packaging logo.
 2. The product color is consistent with the color of the tape packaging box.

| Sign | | | Hebei Chengda WaterTechnology Co., Ltd. | | | |
|----------|---------------|------------|--|---|-------------------------------|----------------------------|
| | Signature | Date | Material | FRP | Projection | |
| Designer | Chengyang Sun | 2024.07.18 | Model | 63" up and down 6" with up and down 4 inch loading and unloading port | Name: FRP tank | |
| Review | Jingwei Hu | 2024.07.18 | Version number: 00 | | Description of Change Version | Drawing No. CD-22-09-27/01 |
| Approve | | | Please don't measure the size of the drawing | | Unit: mm | 1 Page Page 1 |